

PIN CONFIGURATION		
SIDE A	COLOUR	SIDE B
P#1	RED	C#1
P#2	BLACK	C#2
P#3	YELLOW/GREEN	C#3

FINISHED GOOD(CA) PART NO: DESCRIPTION

RCA-1000 XX 01

TYPE OF CA: RCA-1000: POWER CORD 3PIN PLUG TO C13, WITH 1.5SQ.MM CABLE, RATING: 16A 250V, ISI MARKED(IS 1293)

COLOUR OF CA: 01-BLACK

LENGTH OF CA: 0.1 TO XX MTRS

FOR EXAMPLE;
 PART NO: RCA-1000-1-01
 DISC: POWER CORD 3PIN PLUG TO C13
 LENGTH: 1MTR WITH 1.5SQ.MM CABLE
 RATING: 16A 250V

CABLE CONSTRUCTION

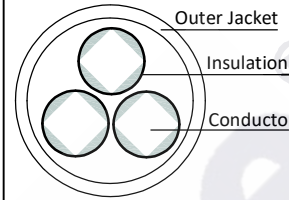

PARAMETERS	
No. of Strands:	30
Conductor Diameter (max):	0.26mm
Conductor Resistance (max):	13.30Ω/Km
Core Colour:	Red, Black and Yellow/Green
Insulation Material:	PVC
Insulation OD (max):	3.40mm
Overall Diameter (max):	9.40mm
Outer Sheath Material:	PVC
Insulation Resistance (min):	3.67MΩ-Km @ 27°C
High Voltage Test (5 Minutes):	Withstand 3KV AC @ Room Temperature

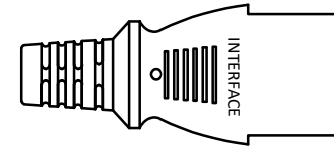
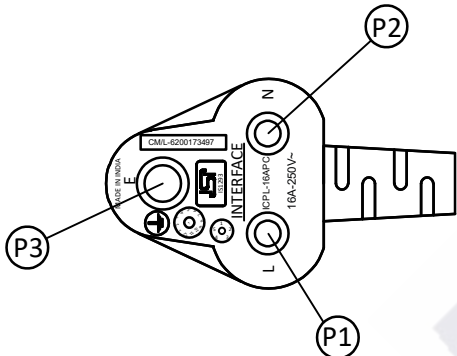
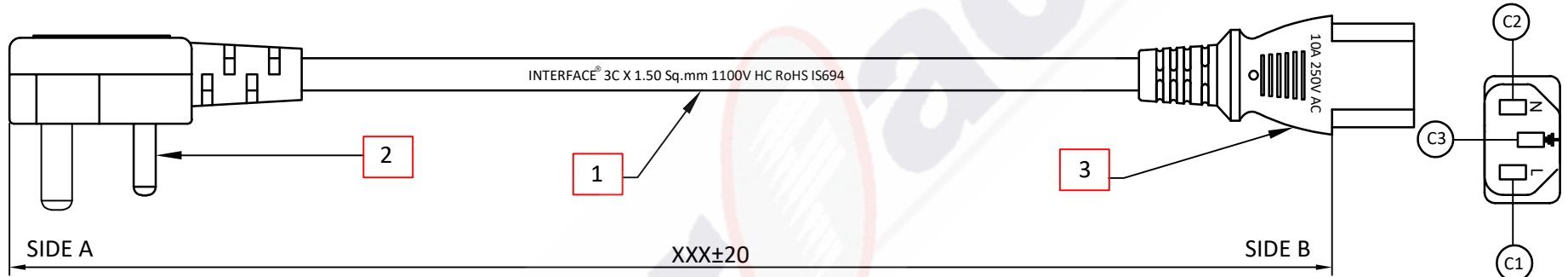

SL NO	DESCRIPTION	QTY
1	3 CORE 1.50SQMM CABLE, BLACK COLOR	1NOS
2	3PIN 16AMP PLUG CNTR(SOLID PINS)-WHITE	1NOS
3	C13 CONNECTOR	1NOS

		Description	3PIN TO C13 16AMPS 250V 1.5SQ.MM		
		Drg No	A4-01-1000-XXX-01		
		ICPL Part No	RCA-1000-XX-01		
Address: B-260,Peenya 2nd stage,Peenya industrial area, Bangalore-560058.		Customer Part No	TBA	Rev	00
Drafted by	MC	Angle of projections	Third angle	Scale	1:1
Checked	RV	Date	24-04-2024	Sheet	1 of 1
Approved	NC	All dimensions are in mm		Size	A4
Tolerance :		Unless otherwise specified for length 0 - 500 - ±5 1000 - 1500 - ±15 500 - 1000 - ±10 1500 - 2000 - ±20			