

PIN CONFIGURATION		
SIDE A	COLOUR	SIDE B
PIN#1	RED	PIN#1
PIN#2	WHITE	PIN#2
PIN#3	GREEN	PIN#3
PIN#4	BLACK	PIN#4
SHELL	DRAIN	SHELL

FINISHED GOOD(CA) PART NO: DESCRIPTION

RCA-700X	XX	01
TYPE OF CA		COLOR OF CA
		BLACK

RCA-7005: USB 2.0 A MALE TO A FEMALE PANEL MOUNT WITH HEX NUT AND SCREW, CABLE ASSEMBLY WITH 26AWG/1P+24AWG/2C CABLE

LENGTH OF CA
0.1 TO XX MTRS

RCA-7004: USB 2.0 A MALE TO A FEMALE PANEL MOUNT WITH HEX NUT AND SCREW, CABLE ASSEMBLY WITH 28AWG/1P+24AWG/2C CABLE

FOR EXAMPLE;

PART NO: RCA-7000-1-01
DISC: USB 2.0 A MALE TO A FEMALE PANEL MOUNT WITH HEX NUT AND SCREW 28AWG/1PR+28AWG/2C USB CABLE LENGTH: 1MTR

CABLE CONSTRUCTION

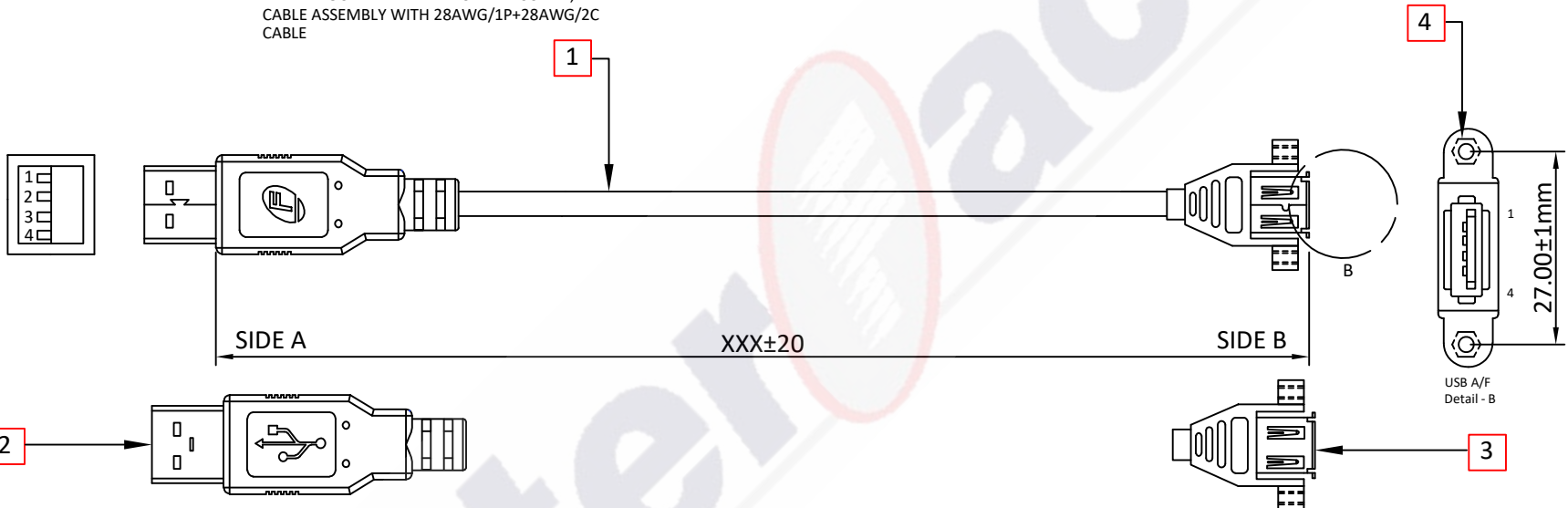
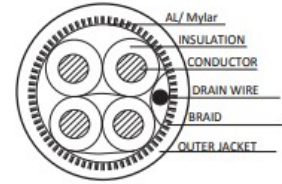

SL NO	DESCRIPTION	QTY
1	USB 2.0 UL 2725 1P*XXAWG+2C*XXAWG+AL.MYLAR +DRAIN+BRAID ROHS COMPLIANT CABLE	1NOS
2	USB A TYPE MALE CONNECTOR	1NOS
3	USB A TYPE FEMALE CONNECTOR	1NOS
4	M3 HEX NUT 2.3MM	2NOS
5	STANDARD M3 SCREW	2NOS

		Description	USB 2.0 A MALE TO A FEMALE PANEL MOUNT WITH HEX NUT AND SCREW		
		Drg No	A4-01-700X-XXX-01		
		ICPL Part No	RCA-700X-XX-01		
Address: B-260,Peenya 2nd stage,Peenya industrial area, Bangalore-560058.		Customer Part No	TBA	Rev	00
Drafted by	MC	Angle of projections	Third angle	Scale	1:1
Checked	RV	Date	17-08-2024	Sheet	1 of 1
Approved	NC	All dimensions are in mm		Size	A4
Tolerance :	Unless otherwise specified for length 0 - 500 - ±5 1000 - 1500 - ±15 500 - 1000 - ±10 1500 - 2000 - ±20	*The document is a property of Interace Connectronics Pvt Ltd and is considered company confidential. Reproduction, unauthorised use, or disclosure of this drawing in whole or in part is prohibited.*			